

REF	O.E.M. #	J&A #	DESCRIPTION	L1	L2	L3
A	UN-141759	225002-000	ASSEMBLY, ROD, POINT DET (M22)	28	12 3/32	12 1/16
B	UN-284475	225002-001	ASSEMBLY, ROD, POINT DET (M23)	28	10 5/8	10 1/2
C	UN-330379	225002-002	ASSEMBLY, ROD, POINT DET (A5)	25 3/4	10 1/2	8 1/2
1A	UN-142168	140083-000	ROD, POINT DET (M22)		12 3/32	
1B	UN-284472	140083-001	ROD, POINT DET (M23)		10 5/8	
1C		140083-002	ROD, POINT DET (A5)		10 1/2	
2A	UN-142169	220045-000	SLEEVE (M22)			12 1/16
2B	UN-284474	220045-001	SLEEVE (M23)			10 1/2
2C		220045-002	SLEEVE (A5)			8 1/2
3	UJ-47903	013000-010	WASHER, SPLIT LOCK, 3/4" Z/P			
4	UM-17854	013100-010	NUT, HEX, 3/4-10 Z/P			

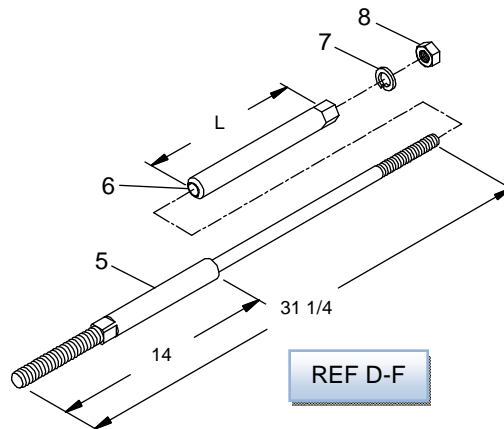

REF	O.E.M. #	J&A #	DESCRIPTION	L
D	UN-285907	225032-000	ASSEMBLY, ROD, POINT DET (M23)	10 1/2
E	UN-208591	225032-001	ASSEMBLY, ROD, POINT DET (M22)	12 1/16
F		225032-002	ASSEMBLY, ROD, POINT DET (M23/22)	12 1/16
5D	UM-285906	140054-000	ROD, POINT DET (M23) FOR -000 AND -002	
5E	UN-208590	140054-001	ROD, POINT DET (M22) FOR -001	
6D	UN-284474	220045-001	SLEEVE (M23) FOR -000	10 1/2
6E	UN-142169	220045-000	SLEEVE (M22) FOR -001 AND -002	12 1/16
7	UJ-47903	013000-010	WASHER, SPLIT LOCK, 3/4" Z/P	
8	UM-17854	013100-010	NUT, HEX, 3/4-10 Z/P	