

SHIFTED LOAD DETECTOR

OUTSIDE DETECTION

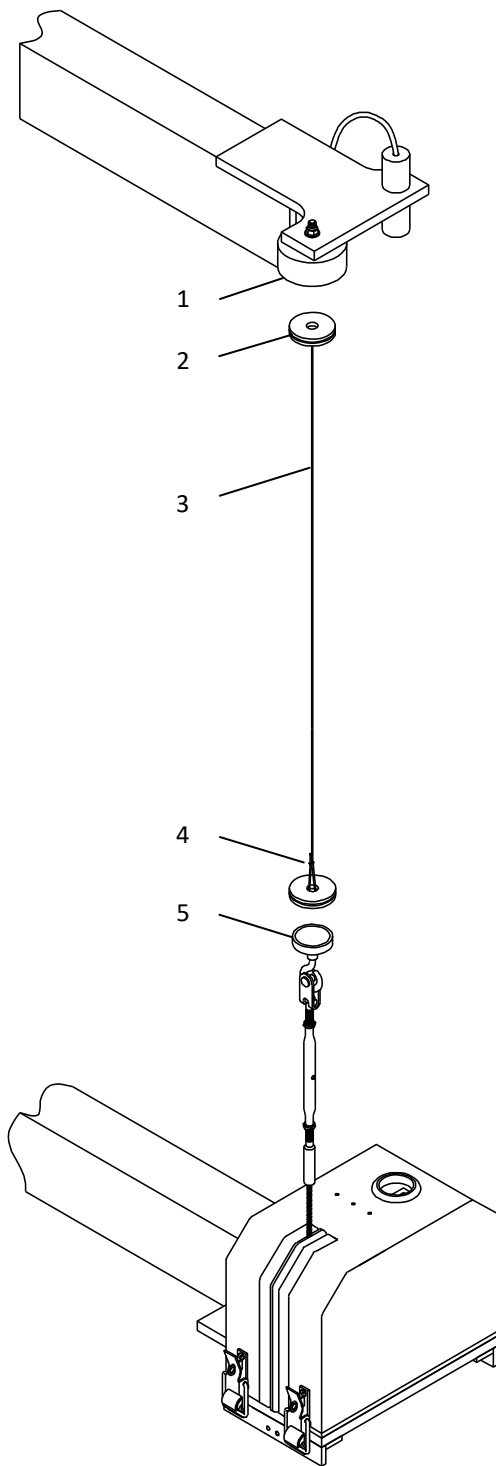

- Eliminate false train stops
- Less than 12 month ROI for retrofit systems
- Trains keep moving with IR backup in place until system can be reset
- Very maintainer friendly design
- “Failsafe” technology monitors sensors and provides vital output
- Adjust easily and arms swing away for track maintenance
- Available as a retrofit to existing sites or as a new installation

REF	J&A #	DESCRIPTION
1	014163-003	MAGNET, 1 3/4 DIA, 117 LBS, W/HOLE
2	141524-000	PUCK, CABLE END, SHIFTED LOAD DETECTOR
3A	014170-001	CABLE, COATED, 1/16-3/32 X 50 FT
3B	014170-002	CABLE, COATED, 1/16-3/32 X 60 FT
3C	014170-003	CABLE, COATED, 1/16-3/32 X 30 FT
3D	014170-004	CABLE, COATED, 1/16-3/32 X 75 FT
4	180758-000	KIT, CABLE ENDS, 1/16 (6 IN PACK)
5	014163-000	MAGNET, 1 3/4 DIA, 125 LBS, W/EYE
6	220078-001	SLEEVED SENSOR, -40 DEG POTTED (TURCK)
7	030100-001	CIRCUIT BOARD, VPD SYSTEM

SHIFTED LOAD DETECTOR

2 TRACK DETECTION

